

# Add six jumper wires to the board

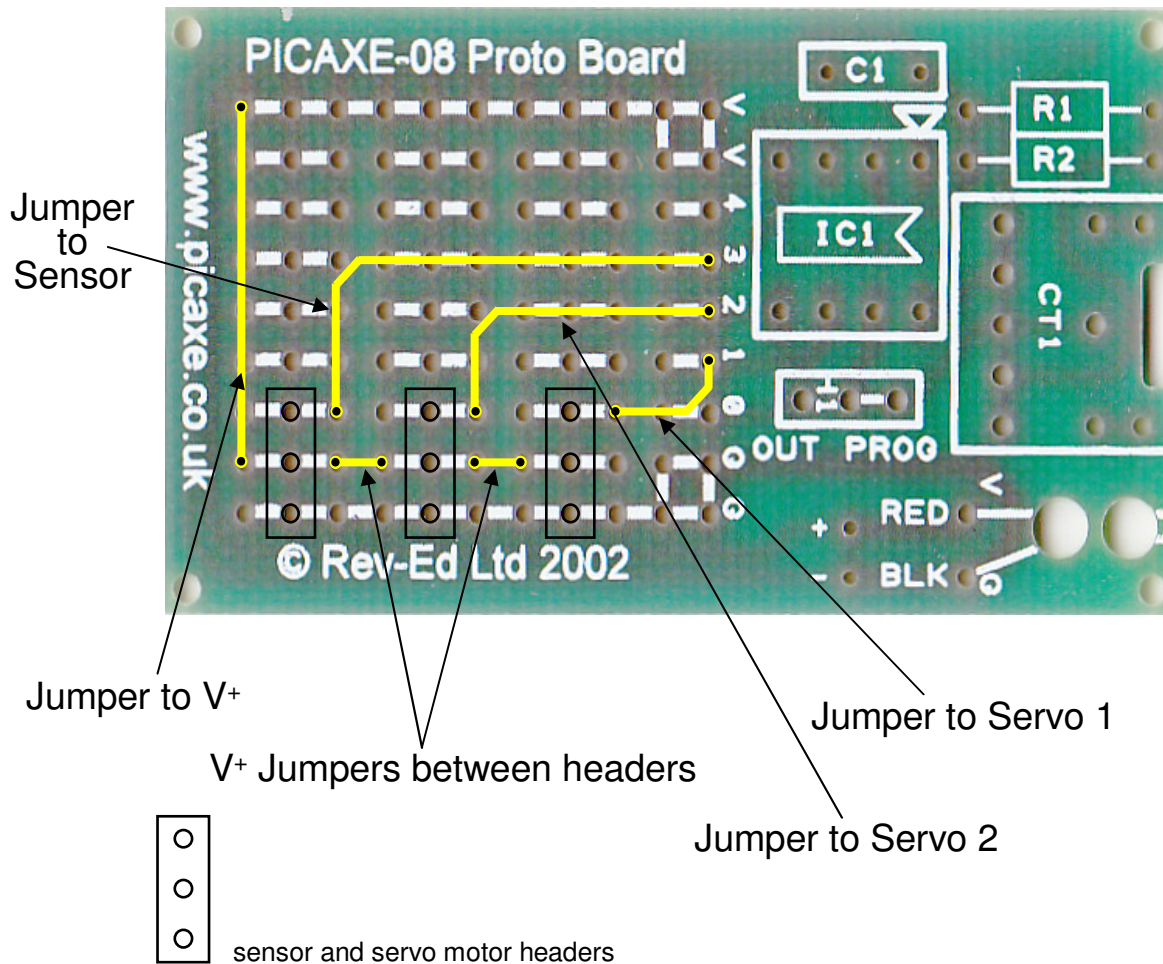

- Use solid bare (un-insulated) #22 wire
- Run wires along top of board
- Put ends through indicated holes, solder, and trim
- Count holes to make sure of ends points
- Be sure wires are not touching when you are done



It is easiest to insert one end of a jumper wire and solder it first. Then you are free to shape and run the jumper to its other end before inserting and soldering it. Exact shape is not important. Ends points and not touching are!

